

DIRECT STEAM KETTLE

FULL JACKETED, STATIONARY
WALL-BRACKET MOUNTED
DEEP DRAWN CONSTRUCTION
MADE IN USA

MODEL LSWT

STANDARD FEATURES

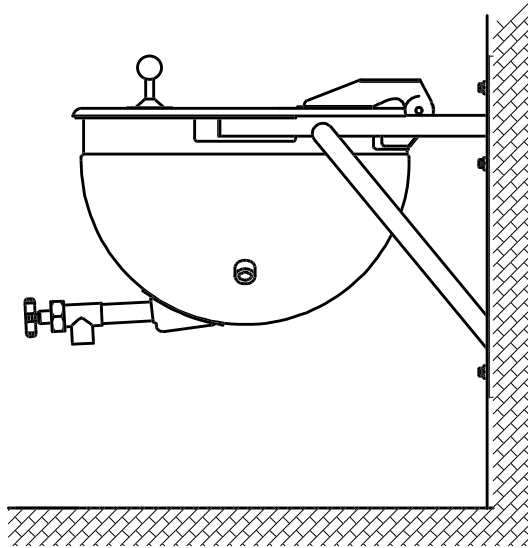

Model LSWT

- ◆ **The Legion 316 Kettle System**
 - ◇ 316 stainless liner
 - ◇ 316 stainless draw-off tube and welds
 - ◇ 316 stainless 1 1/2" compression draw-off valve
- ◆ 304 stainless kettle jacket
- ◆ 304 stainless support arms, seam welded to jacket
- ◆ 304 stainless, one piece, domed cover, actuator-assisted on 40 - 100 gallon
- ◆ 30 psi operating pressure up to 80 gallon; 25 psi for 100 gallon
- ◆ Perforated disk strainer, 1/4"

Legion equipment is built to comply with applicable standards for manufacturers. Approval agencies may include ASME, NSF, UL, ETL, AGA, CSA, CGA, and others. Legion reserves the right of design improvement or modification as warranted.

MODELS AND CAPACITIES			OPTIONAL FEATURES AND ACCESSORIES	
			See price list for supplemental information regarding options	
LSWT-20	20 gal.	(76 l.)	<input type="checkbox"/> Single or double fill faucet with bracket & 12 or 18" swing nozzle	<input type="checkbox"/> Connection plumbing parts kit
LSWT-25	25 gal.	(95 l.)	<input type="checkbox"/> 48" flexible spray hose assembly (vinyl or stainless) for use with dual or single fill faucet	<input type="checkbox"/> Draw-off drain hose
LSWT-40	40 gal.	(151 l.)	<input type="checkbox"/> Faucet bracket	<input type="checkbox"/> Measuring strip
LSWT-50	50 gal.	(189 l.)	<input type="checkbox"/> Automatic water filling meter	<input type="checkbox"/> Perforated disk strainer 1/8" holes
LSWT-60	60 gal.	(227 l.)	<i>(Call for information regarding additional faucet options)</i>	<input type="checkbox"/> Kettle care kit
LSWT-80	80 gal.	(303 l.)	<input type="checkbox"/> Single basket insert, 20 - 40 gallon	<input type="checkbox"/> Mixer/Agitator, 2 speed
LSWT-100	100 gal.	(379 l.)	<input type="checkbox"/> Tri-basket insert	<input type="checkbox"/> In-wall carrier for wall mounting
Select draw-off valve: <input type="checkbox"/> 1 1/2" <input type="checkbox"/> 2" <input type="checkbox"/> 3" With: <input type="checkbox"/> compression <input type="checkbox"/> ball type fitting See price list for other draw-off options.			<input type="checkbox"/> Nylon bag insert with spreader ring	Prison/Security Options:
			<input type="checkbox"/> Lift-off cover	<input type="checkbox"/> Fastener (<i>nut for draw-off</i>)
			<input type="checkbox"/> 1 piece actuator-assisted cover, 20 - 25 gallon	<input type="checkbox"/> Draw-off nut driver tool
			<input type="checkbox"/> 2 piece hinged cover	<input type="checkbox"/> Lockable lid
			<input type="checkbox"/> Higher operating pressure	<input type="checkbox"/> Reinforced bar rim
			<input type="checkbox"/> Air eliminator valve	
			<input type="checkbox"/> Pressure reducing valve	
			<input type="checkbox"/> Full body insulation	

Revision 999



LEGION The Finest American Quality Since 1897

LEGION INDUSTRIES, INC. ♦ 69 MAIN ST. ♦ DALLAS, PA 18612 ♦ (800) 833-9803 ♦ (570) 675-1575 ♦ FAX: (570) 675-7551

MODEL LSWT

FULL JACKETED, STATIONARY
WALL-BRACKET MOUNTED
DEEP DRAWN CONSTRUCTION
MADE IN USA

DIRECT STEAM KETTLE

DRAWING REPRESENTS MODEL LSWT-60

Q = NPT STEAM INLET
R = NPT STEAM RETURN

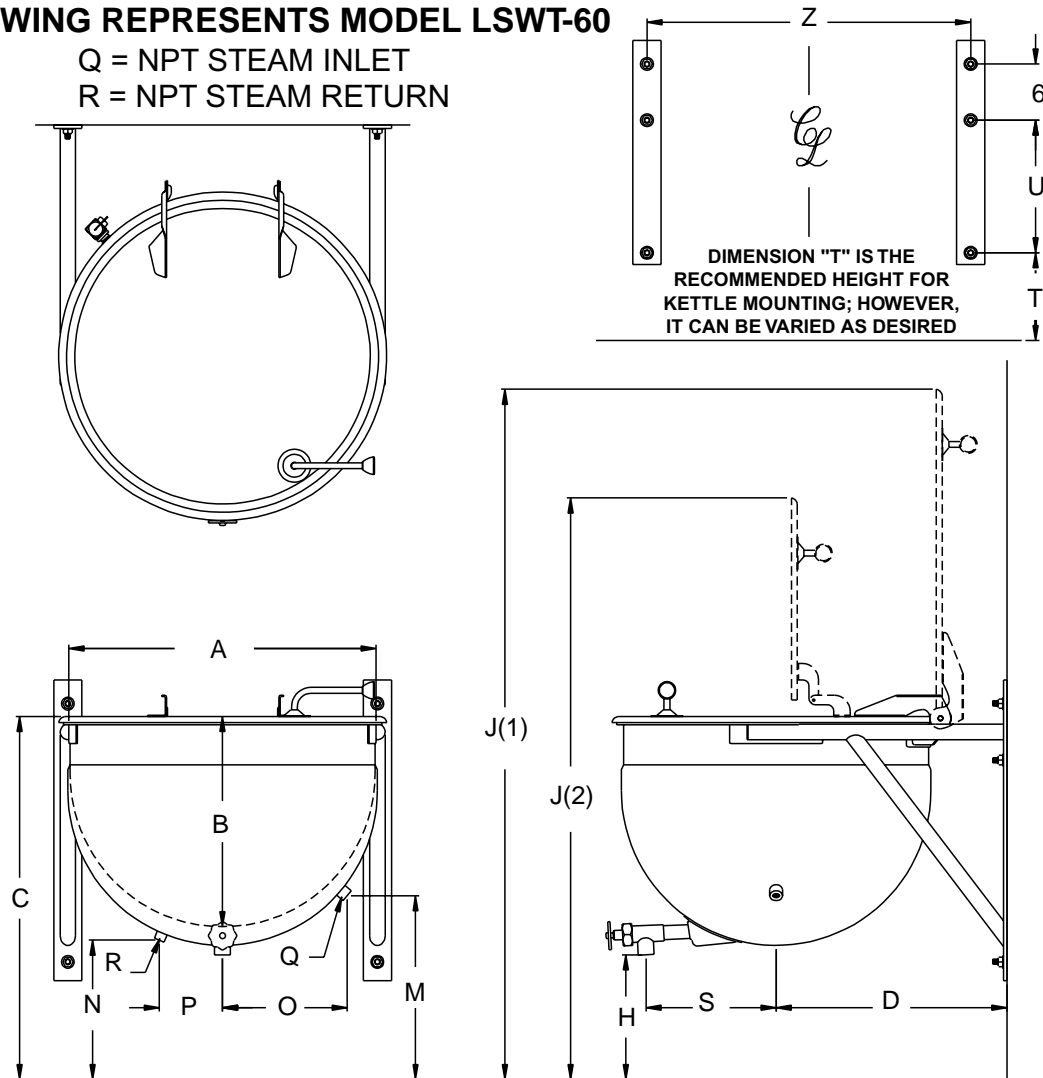

MODEL LSWT DIMENSIONS

GAL.	A	B	C*	D	H*	J1*	J2*	M	N	O	P	Q	R	S*	T	U	Z
20	23.0	15.0	31.4	18.0	13.9	57.4	47.5	17.8	15.0	8.8	5.0	.75	.50	13.0	8.6	16.5	23.5
25	25.5	15.5	30.0	19.3	13.0	58.5	48.0	16.4	14.2	8.7	5.3	.75	.50	13.0	7.3	16.5	26.0
40	29.5	19.0	35.3	21.8	13.3	67.8	58.8	17.3	14.5	10.2	6.0	.75	.50	14.0	7.5	21.5	30.0
50	29.5	21.8	36.3	21.8	13.3	68.8	61.0	17.3	14.5	10.2	6.0	1.00	.75	14.0	8.5	21.5	30.0
60	32.5	22.3	38.2	23.8	13.9	73.7	62.9	19.8	15.3	12.6	6.4	1.00	.75	14.0	10.5	21.5	33.0
80	39.0	22.0	37.4	28.0	13.3	79.4	62.3	19.5	14.4	14.3	6.4	1.00	.75	17.8	9.6	21.5	39.5
100	44.0	22.5	38.3	30.5	13.5	85.3	65.6	18.3	15.8	13.7	9.8	1.25	.75	19.7	10.5	21.5	44.5

*Dimensions on these drawings are applicable only when using a 1.5" diameter draw-off valve. If a 2" or 3" diameter draw-off valve is required, contact Legion for applicable dimensions.

Revision 999



LEGION The Finest American Quality Since 1897

LEGION INDUSTRIES, INC. ♦ 69 MAIN ST. ♦ DALLAS, PA 18612 ♦ (800) 833-9803 ♦ (570) 675-1575 ♦ FAX: (570) 675-7551