

# Insulated Tilting Skillet

**Electric  
Insulated for Safety™  
10° Tilting, Leg Mounted  
Made in USA**

# Combi-Pan® Model CS

## Standard Features



**Model CS41-9**  
(with optional drain hose and spray hose assembly)

- ◆ 316L stainless food contact zone with:
  - ◇ 316 stainless 1.5" compression draw-off
- ◆ 304 stainless seam welded pan body with:
  - ◇ 10° tilting pan, 31" working height
  - ◇ Food pan holder under draw-off
  - ◇ Insulated sides and bottom
  - ◇ Rear drip collector on pan body
  - ◇ Tapered access rim
  - ◇ 240V, three phase (3φ) standard
- ◆ Adjustable thermostat (175°F to 400°F)
- ◆ High limit safety thermostat
- ◆ Patented 304 stainless safety lid, seam welded with:
  - ◇ Actuator-assisted counterbalance
  - ◇ Full width condensate drip shield
  - ◇ Full width rear steam vent
  - ◇ Dual side-mounted safety handles
- ◆ 304 stainless, seam welded component enclosure
- ◆ 304 stainless, seam welded tubular frame construction
- ◆ Adjustable flanged feet (*flanged front, bullet rear*)
- ◆ Approved for use as a fryer

Legion equipment is built to comply with applicable standards for manufacturers. Approval agencies may include ASME, NSF, UL, ETL, AGA, CSA, CGA and others. Legion reserves the right of design improvement or modification as warranted.

## Models and Capacities

Model	2.5" Insert Pans	Cooking Baskets	Griddle Area (in. <sup>2</sup> )	Kettle (Gals.)	Frying Oil (lbs.)	Oven Volume (ft. <sup>3</sup> )
CS28-5	2	0	703	15.2	70	2.0
CS28-7	2	2	703	21.3	70	2.8
CS28-9	2	2	703	27.4	70	3.7
CS28-11	2	2	703	33.5	70	4.5
CS28-14	2	2	703	42.6	70	5.7
CS41-5	3	0	1029	22.3	105	3.0
CS41-7	3	3	1029	31.2	105	4.2
CS41-9	3	3	1029	40.1	105	5.4
CS41-11	3	3	1029	49.0	105	6.6
CS41-14	3	3	1029	62.4	105	8.4

## Optional Features and Accessories

See price list for supplemental information regarding options

### Faucet Options:

\_48" flexible spray hose assembly (vinyl or stainless) for use with single ball valve mounted to frame

\_48" flexible spray hose assembly (vinyl or stainless) for use with dual faucet & bracket

\_Automatic water filling meter  
(Call for information regarding additional faucet options)

### Prison/Security Options:

\_Fasteners (screws & nuts)

\_Nut driver tool

\_Draw-off nut driver tool

\_Screw driver tool

\_Lockable control cover

\_Lockable lid

\_Draw-off protection

### Feet:

\_Adjustable flanged feet (rear feet)

\_Casters (two each locking/non-locking type) & restraining devices

\_Restraining device kit

### Other Options:

\_Knockdown capability for 26" x 66" opening (*shipped assembled*)

\_Electric timer with buzzer

### Accessories:

\_Perforated or solid 12 x 20 pans, 2½, 4 or 6"

\_Perforated draw-off strainer

\_Draw-off drain spout

\_Perforated cooking/steaming basket (11" x 20½" x 5")

\_Draw-off drain with 6' hose

\_#10 Can holder for draw-off

\_Flat bottom scoop

\_Fry scoop

\_Care kit

\_3 part tool for cleaning cooking surface

Select draw-off valve:  1.5"  2"  3"

With:  compression  ball type fitting

*See price list for other draw-off options.*

Select Voltage:  208V  240V  380V  415V  440V  480V

Select Phase:  1φ  3φ

Revision 1102

**Legion Industries, Inc., Post Office Box F, Dallas, PA 18612, (800) 833-9803, (570) 675-1595,  
Fax: (570) 675-7551, www.legionindustries.com, sales@legionindustries.com**

# Combi-Pan® Model CS

Electric  
Insulated for Safety™  
10° Tilting, Leg Mounted  
Made in USA

# Insulated Tilting Skillet

DRAWING REPRESENTS MODEL CS28-9 WITH STANDARD 1 1/2" DRAW-OFF  
AND OPTIONAL SINGLE BALL VALVE AND SPRAY HOSE ASSEMBLY

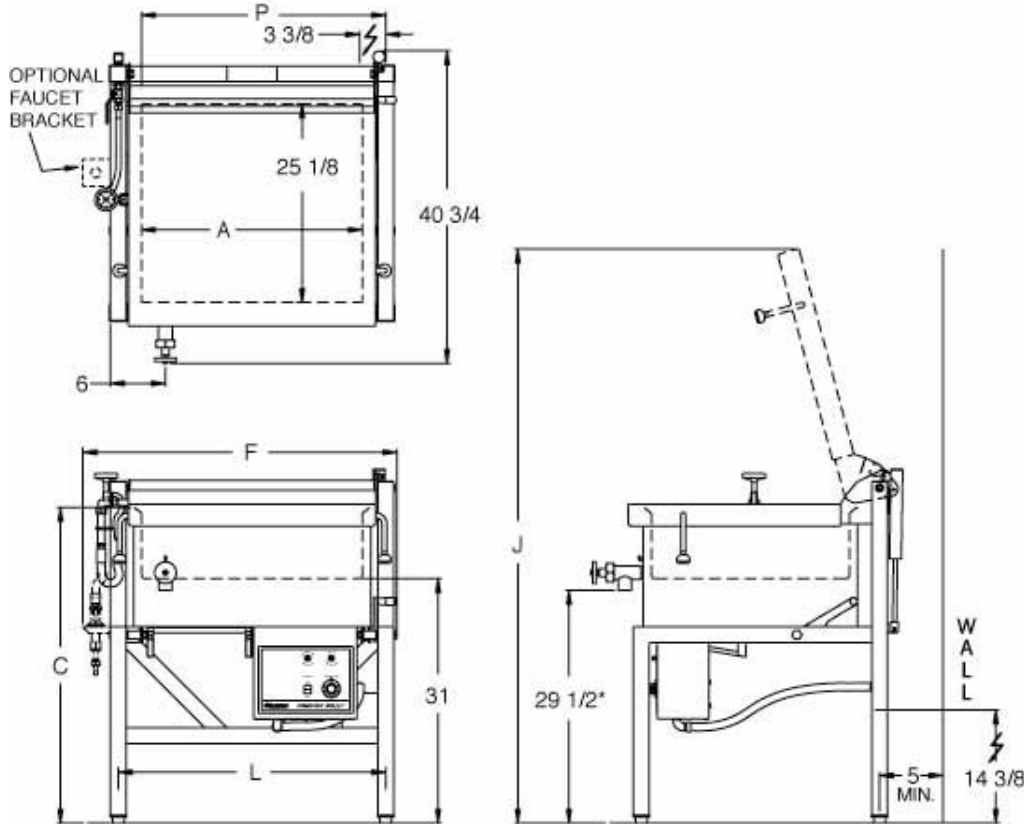

COMBI-PAN® TILTING SKILLET DIMENSIONS

Model*	Depth	A (PAN ID)	C	F	J	L	P (DRAIN)	Model*	Depth	A (PAN ID)	C	F	J	L	P (DRAIN)
CS28-5	5	28.0	36.0	40.0	68.8	34.0	32.4	CS41-5	5	41.0	36.0	53.0	68.8	47.0	45.4
CS28-7	7	28.0	38.0	40.0	70.8	34.0	32.4	CS41-7	7	41.0	38.0	53.0	70.8	47.0	45.4
CS28-9	9	28.0	40.0	40.0	72.8	34.0	32.4	CS41-9	9	41.0	40.0	53.0	72.8	47.0	45.4
CS28-11	11	28.0	42.0	40.0	74.8	34.0	32.4	CS41-11	11	41.0	42.0	53.0	74.8	47.0	45.4
CS28-14	14	28.0	45.0	40.0	77.8	34.0	32.4	CS41-14	14	41.0	45.0	53.0	77.8	47.0	45.4

\*Dimensions on these drawings are applicable only when using a 1.5" diameter draw-off valve. If a 2" or 3" diameter draw-off valve is required, contact Legion for applicable dimensions.

COMBI-PAN® TILTING SKILLET ELECTRICAL SPECIFICATIONS (Amperes per Leg)

Model*	kW	208 Volt		240 Volt		380 Volt		415 Volt		440 Volt		480 Volt	
		1φ	3φ	1φ	3φ	1φ	3φ	1φ	3φ	1φ	3φ	1φ	3φ
CS28-(-)	14.4	69.2	40.0	60.0	34.6	37.9	21.9	34.7	20.0	32.7	18.9	30.0	17.3
	19.2*	92.3	53.3	80.0	46.2	50.5	29.2	46.3	26.7	43.6	25.2	40.0	23.1
CS41-(-)	21.0	101.0	58.3	87.5	50.5	55.3	31.9	50.6	29.2	47.7	27.6	43.8	25.3
	27.6*	132.7	76.6	115.0	66.4	72.6	41.9	66.5	38.4	62.7	36.2	57.5	33.2

\*Note: Add prefix H to above models to designate High Output Models, i.e. CS28-7 becomes HCS28-7  
U.S. Patent Nos. 5,553,531, 5,865,101 & 5,964,145

Revision 1102

**Legion Industries, Inc., Post Office Box F, Dallas, PA 18612, (800) 833-9803, (570) 675-1595,  
Fax: (570) 675-7551, www.legionindustries.com, sales@legionindustries.com**