

Insulated Tilting Skillet

**Gas-Fired
Insulated for Safety™
10° Tilting, Leg Mounted
Made in USA**

Combi-Pan® Model CSG

Standard Features



**Model CSG41-9
(with optional can holder)**

- ◆ 316L stainless food contact zone with:
 - ◇ 316 stainless 1.5" compression draw-off
- ◆ 304 stainless seam welded pan body with:
 - ◇ 10° tilting pan, 31" working height
 - ◇ Food pan holder under draw-off
 - ◇ Insulated sides and bottom
 - ◇ Rear drip collector on pan body
 - ◇ Tapered access rim
 - ◇ High efficiency infrared burners with electronic ignition
 - ◇ 120V, single phase (1φ) standard
- ◆ Adjustable thermostat (175°F to 400°F)
- ◆ High limit safety thermostat
- ◆ Patented 304 stainless safety lid, seam welded with:
 - ◇ Actuator-assisted counterbalance
 - ◇ Full width condensate drip shield
 - ◇ Full width rear steam vent
 - ◇ Dual side-mounted safety handles
- ◆ 304 stainless, seam welded component enclosure
- ◆ 304 stainless, seam welded tubular frame construction
- ◆ Adjustable flanged feet (*flanged front, bullet rear*)
- ◆ Approved for use as a fryer

Legion equipment is built to comply with applicable standards for manufacturers. Approval agencies may include ASME, NSF, UL, ETL, AGA, CSA, CGA and others. Legion reserves the right of design improvement or modification as warranted.

Models and Capacities

Model	2.5" Insert Pans	Cooking Baskets	Griddle Area (in. ²)	Kettle (Gals.)	Frying Oil (lbs.)	Oven Volume (ft. ³)
CSG28-5	2	0	703	15.2	70	2.0
CSG28-7	2	2	703	21.3	70	2.8
CSG28-9	2	2	703	27.4	70	3.7
CSG28-11	2	2	703	33.5	70	4.5
CSG28-14	2	2	703	42.6	70	5.7
CSG41-5	3	0	1029	22.3	105	3.0
CSG41-7	3	3	1029	31.2	105	4.2
CSG41-9	3	3	1029	40.1	105	5.4
CSG41-11	3	3	1029	49.0	105	6.6
CSG41-14	3	3	1029	62.4	105	8.4

Optional Features and Accessories

See price list for supplemental information regarding options

Faucet Options:

- _48" s/s flexible spray hose assembly (vinyl or stainless) for use with single ball valve mounted to frame
 - _48" s/s flexible spray hose assembly (vinyl or stainless) for use with dual faucet & bracket
 - _Automatic water filling meter
- (Call for information regarding additional faucet options)*

Prison/Security Options:

- _Fasteners (screws & nuts)
- _Nut driver tool
- _Draw-off nut driver tool
- _Screw driver tool
- _Lockable control cover
- _Lockable lid
- _Draw-off protection

Feet:

- _Adjustable flanged feet (rear feet)
- _Restraining device kit
- _Gas quick disconnect 3/4"
- _Flexible gas hose 3/4" x 60"

Feet:

- _Casters (two each locking/non-locking type) & restraining devices

Other Options:

- _Electric timer with buzzer
- _Knockdown capability for 26" x 66" opening (*shipped assembled*)

Accessories:

- _Perforated cooking/steaming basket (11" x 20 1/2" x 5")
- _Perforated or solid 12 x 20 pans, 2 1/2, 4 or 6"
- _Perforated draw-off strainer
- _Draw-off drain spout
- _Draw-off drain with 6' hose
- _#10 Can holder for draw-off
- _Flat bottom scoop
- _Fry scoop
- _Care kit
- _3 part tool for cleaning cooking surface

Select draw-off valve: 1.5" 2" 3"
with: compression ball type fitting

See price list for other draw-off options.

Select Voltage: 120V 208V 240V

Select Gas: Natural LP Other

Revision 1102

**Legion Industries, Inc., Post Office Box F, Dallas, PA 18612, (800) 833-9803, (570) 675-1595,
Fax: (570) 675-7551, www.legionindustries.com, sales@legionindustries.com**

Combi-Pan® Model CSG

Gas-Fired
Insulated for Safety™
10° Tilting, Leg Mounted
Made in USA

Insulated Tilting Skillet

DRAWING REPRESENTS MODEL CSG28-9 WITH STANDARD 1 1/2" DRAW-OFF
AND OPTIONAL SINGLE BALL VALVE AND SPRAY HOSE ASSEMBLY

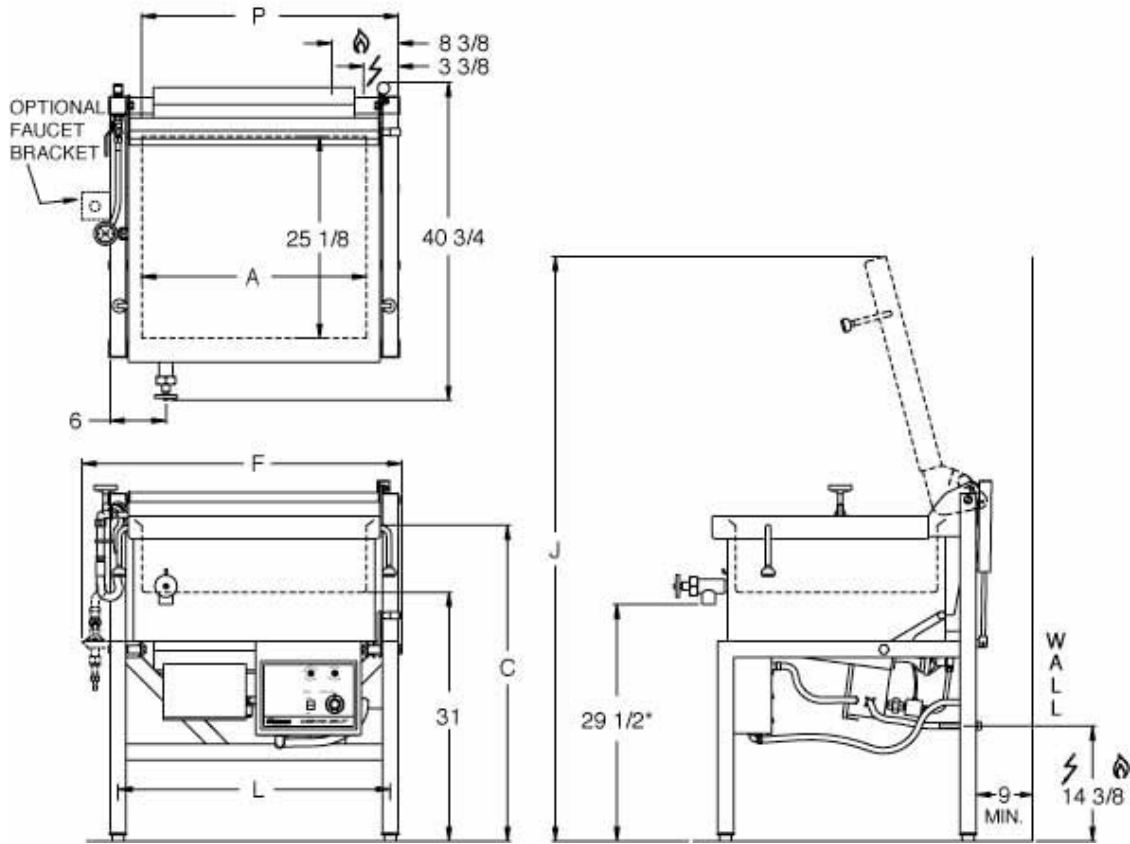

COMBI-PAN® TILTING SKILLET DIMENSIONS

Model*	Depth	A (PAN ID)	C	F	J	L	P (DRAIN)	Model*	Depth	A (PAN ID)	C	F	J	L	P (DRAIN)
CSG28-5	5	28.0	36.0	40.0	68.8	34.0	32.4	CSG41-5	5	41.0	36.0	53.0	68.8	47.0	45.4
CSG28-7	7	28.0	38.0	40.0	70.8	34.0	32.4	CSG41-7	7	41.0	38.0	53.0	70.8	47.0	45.4
CSG28-9	9	28.0	40.0	40.0	72.8	34.0	32.4	CSG41-9	9	41.0	40.0	53.0	72.8	47.0	45.4
CSG28-11	11	28.0	42.0	40.0	74.8	34.0	32.4	CSG41-11	11	41.0	42.0	53.0	74.8	47.0	45.4
CSG28-14	14	28.0	45.0	40.0	77.8	34.0	32.4	CSG41-14	14	41.0	45.0	53.0	77.8	47.0	45.4

*Dimensions on these drawings are applicable only when using a 1.5" diameter draw-off valve. If a 2" or 3" diameter draw-off valve is required, contact Legion for applicable dimensions.

**Note: Vertical dimensions of 11" deep pan may be reduced by 2" to match 9" deep pan

COMBI-PAN® TILTING SKILLET GAS SPECIFICATIONS

Model*	Gas Rating - Btu Input		Gas Pressure & Piping Specifications	
	Natural	Propane	Natural	Propane
CSG28-(-)	100,000	111,000	Piping - 3/4" IPS Inlet Pressure Range, 5.0 - 7.0 inches w.c.	Piping - 3/4" IPS Inlet Pressure Range, 12.0 - 14.0 inches w.c.
CSG41-(-)	132,000	149,000	Outlet Pressure Setting, 3.5 inches w.c.	Outlet Pressure Setting, 10.0 inches w.c.

U.S. Patent Nos. 5,553,531, 5,865,101, 5,964,145

Revision 1102

**Legion Industries, Inc., Post Office Box F, Dallas, PA 18612, (800) 833-9803, (570) 675-1595,
Fax: (570) 675-7551, www.legionindustries.com, sales@legionindustries.com**